

3/2 way pneumatic cartridge solenoid valve



- Compact design with 11 mm width per station
- Orifices from 0.5 mm (10 bar) to 1.2 mm (1.5 bar)
- High durability and reliability
- Low power consumption, as well as optional ATEX Ex ib version
- Design for optimum integration

Customer specific applications are becoming more complex. Size, fluidic performance, low power consumption and cost efficiency are critical criteria. Therefore the demands on the components used are increasing. Type 6164 was developed with the goal, to simplify pneumatic control with optimum integration of a pilot valve in block and plastic moulding parts. Thus, making a more compact design possible.

This valve sets new standards with its uncompromising reliability, above average life cycle span and excellent fluidic characteristics.

Various certifications and conformities make the use of the valve in medical applications such as media multiplexers in dental technology and oxygen control in respirators possible.

Circuit function C

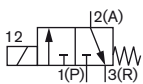

3/2 way direct-acting, impulse solenoid valve, normally closed

Circuit function D

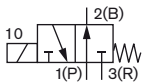

3/2 way direct-acting solenoid valve, normally open

Circuit function T

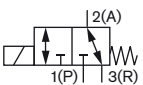

3/2 way direct-acting solenoid valve, flow direction optional

Technical data		
Orifice and pressure range	DN0.5 mm (Vac-9 bar) ¹⁾ DN1.0 mm (Vac-5 bar) ¹⁾	DN0.8 mm (Vac-7.5 bar) ¹⁾ DN1.2 mm (Vac-1.5 bar) ¹⁾
Permissible leakage	Vac- 10 bar (Dependent on the version used) ¹⁾²⁾	
Body material	PEEK	
Seal material	FKM	
Medium	neutral gases	
Medium temperature	FKM Low temperature version	
	- 10 bis + 55 °C - 20 bis + 55 °C	
Ambient temperature	FKM Low temperature version	
	- 10 to + 55 °C ³⁾ - 20 to + 55 °C ³⁾	
Typical life span	100.000.000 switching cycles (accordance to endurance tests) ⁴⁾	
Port connection	▪ Bürkert-Cartridge-Connection	
Electrical connection	▪ Plug / Solder ▪ Flying leads	
Operation voltage	12 and 24 V DC (other voltages on request)	
Voltage tolerance	± 10 %	
Power consumption	0.7 W 2.8 W/0.3 W (with external electric power reduction) 0.3 W (for ExI version)	
Duty cycle	100 % ED continuous rating	
Installation	as required	
Protection class	depending on the electrical connection when installed	
	Pins Special plug Leads	
	IP00 IP40 IP54	
Response times	Measurement at valve outlet acc. to DIN ISO 12238:2001	
	Open Closed	
	< 5ms (pressure rise 0 - 10 %) < 5ms (pressure drop 100 - 90 %)	
Switching frequency	16 Hz	
Switching noise	42dB ⁵⁾	
Weight	6 g (standard version)	
Approvals and conformity on request	BVS 16 ATEX E 088 X: II 2G Ex ib IIC T6...T4 Gb II 2D Ex ib IIIB T155 °C Db IECEX BVS 16.0053 X: Ex ib IIC T6...T4 Gb Ex ib IIIB T155 °C Db UL class 2 Oxygen compatible	

¹⁾ VAC corresponds to -0.8 bar relative

²⁾ Overpressure to the atmospheric pressure

³⁾ Depending on installation conditions (see manual), higher temperatures on request

⁴⁾ Life span is dependent on temperature, pressure, sealing material and operating conditions

⁵⁾ According to ISO3745, testing environment in brass manifold, free-hanging

Materials

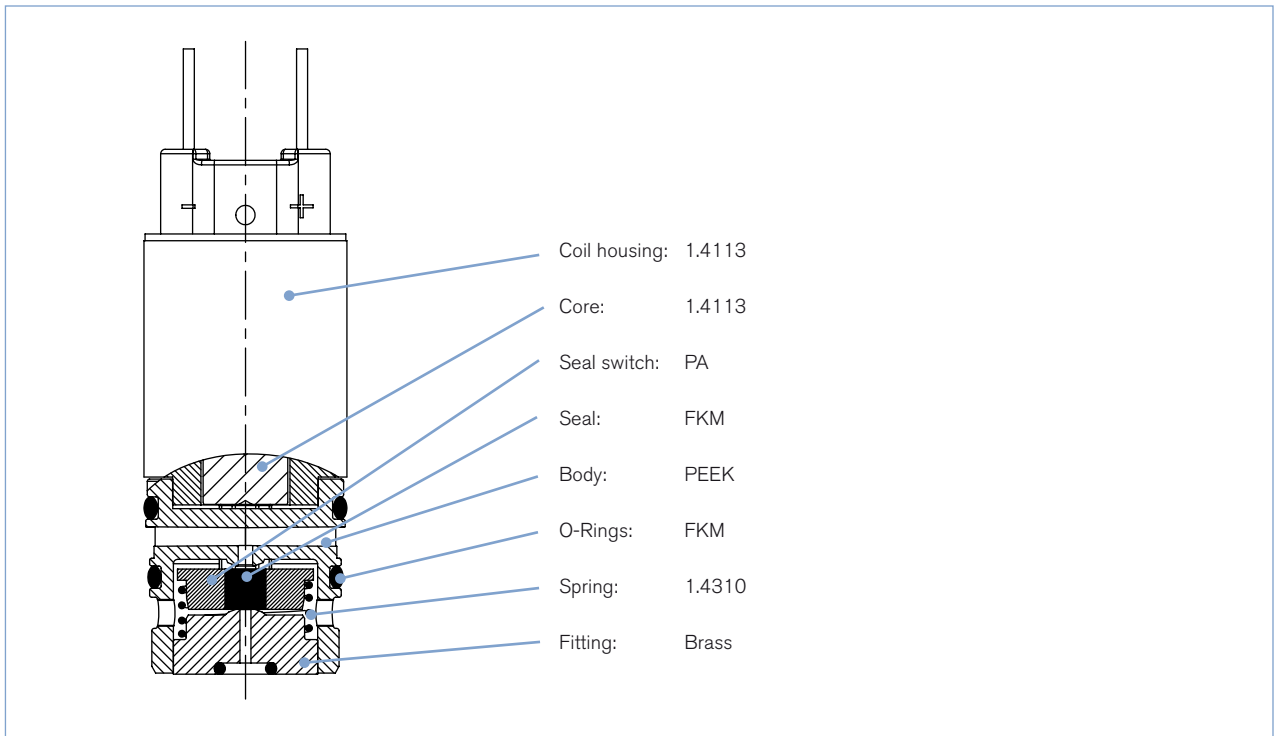

Port connection

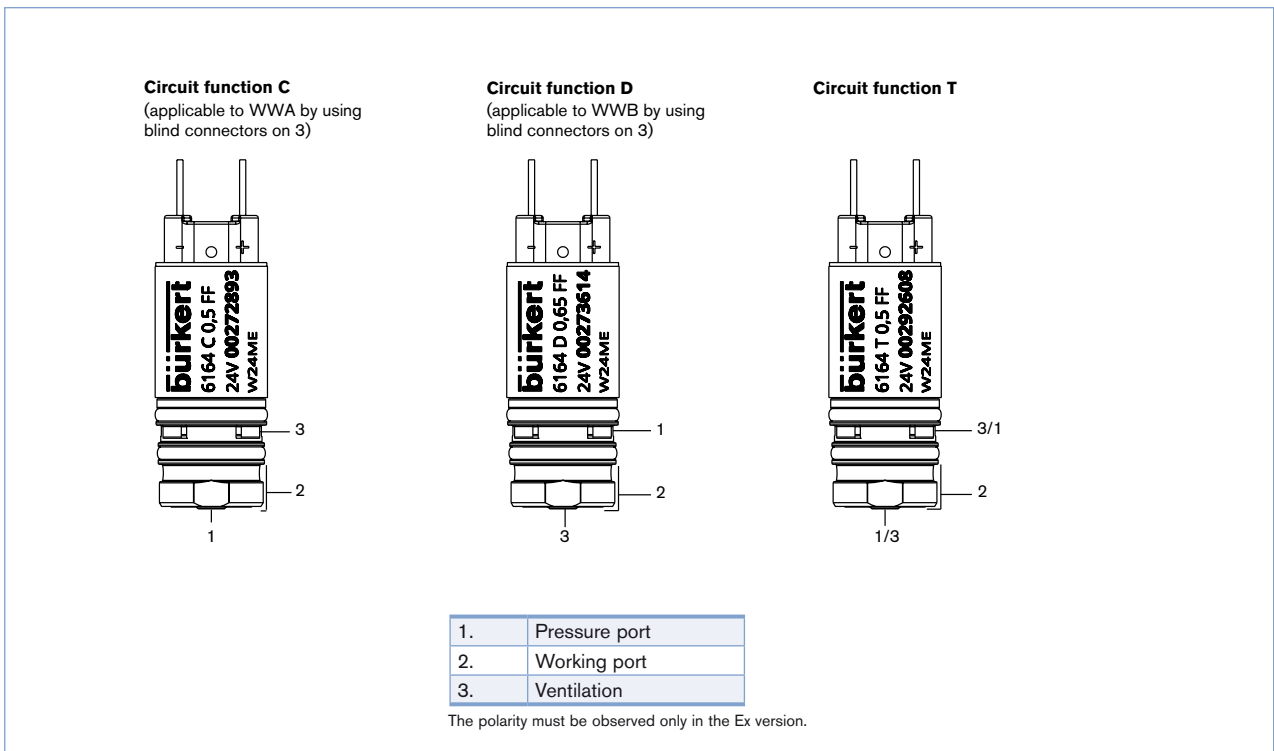

Defining of the installation area

Fully sunken cartridge

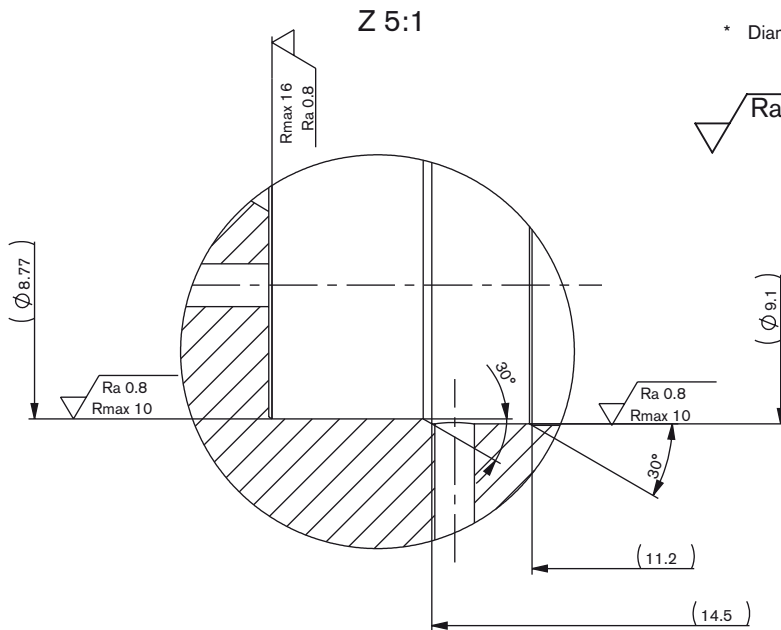
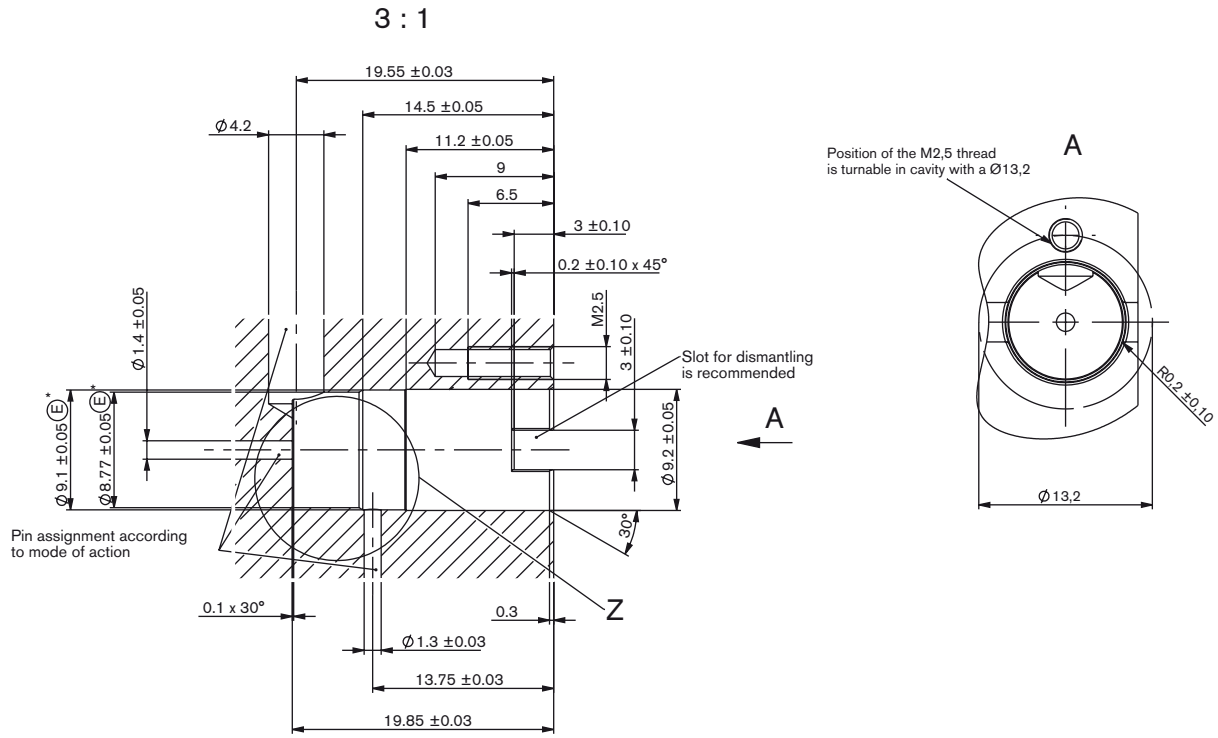

* Diameter tolerance acc. to ISO 14405 (E)

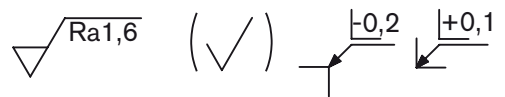

Defining of the installation area

Half sunken Cartridge with retaining bracket

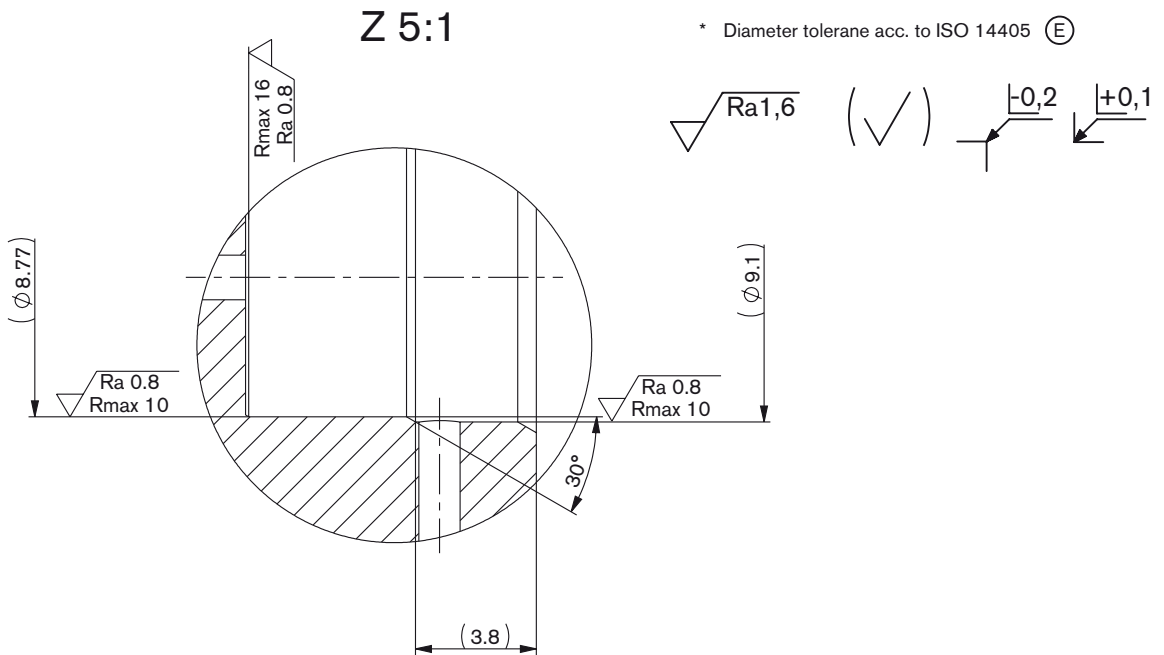
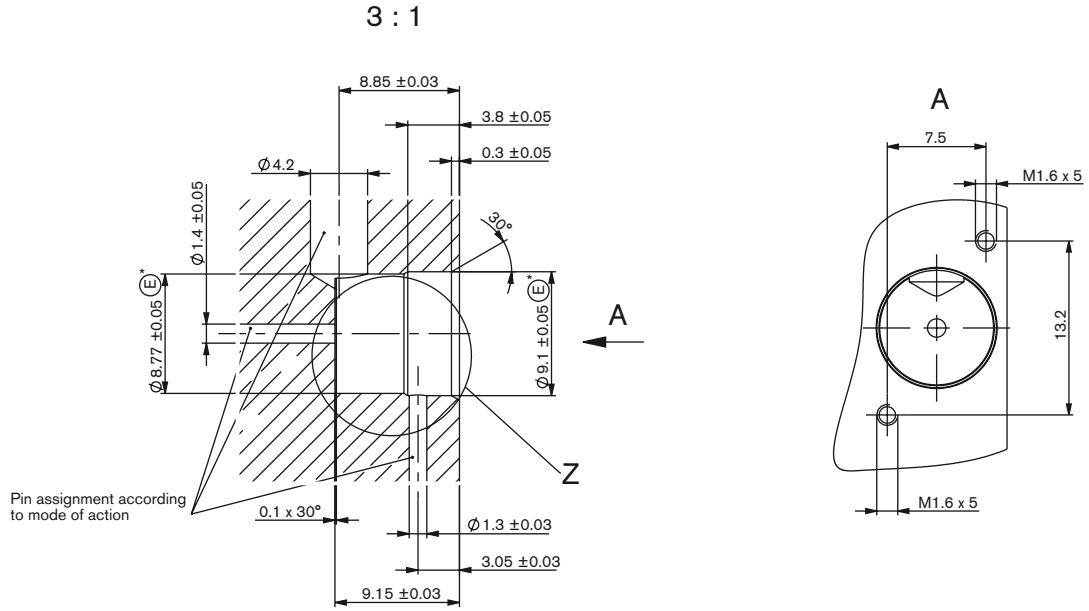

Dimensions [mm]

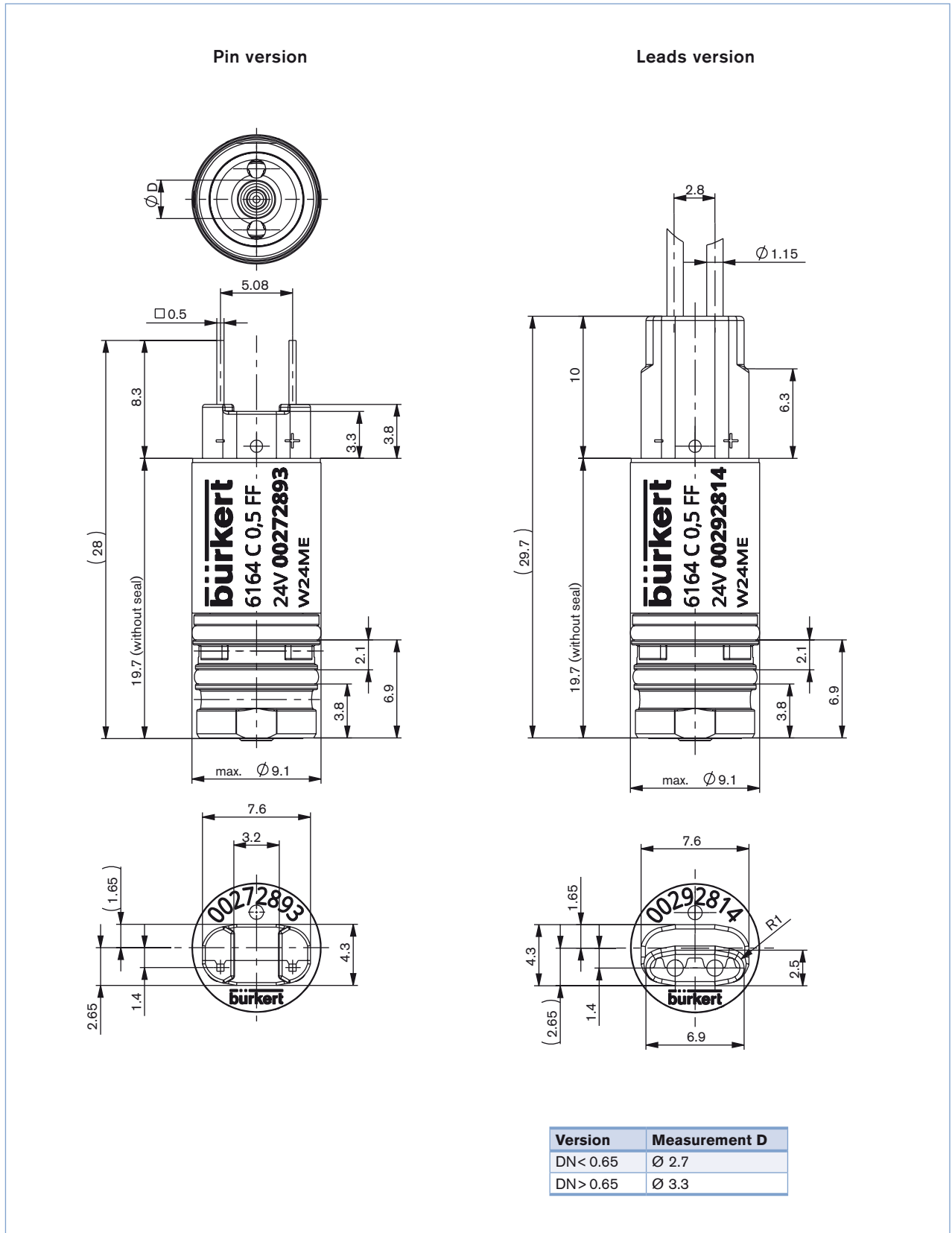

Ordering chart

Circuit function	Port connection	Orifice ventilation 1-2	Orifice ventilation 2-3	Q_{Nn} value 1-2 air [l/min] ³⁾	Q_{Nn} value 2-3 air [l/min] ³⁾	Pressure range [bar]	Voltage	Power rating [W]	Article no. with connection pin
C 	Bürkert Cartridge port connection	0.5	0.65	6	9.5	Vac-9 ¹⁾	12	0.7	273612
		0.5	0.65	6	9.5	Vac-9 ¹⁾	24	0.7	272893
		0.5	0.65	6	9.5	2.5-10	24	0.7	281022
		0.8	1.1	16	20	Vac-7.5 ¹⁾	24	2.8/0.3 ²⁾	285701
		1.0	1.1	20	20	Vac-5 ¹⁾	24	2.8/0.3 ²⁾	285700
		1.2	1.1	25	22	Vav-1.5 ¹⁾	24	2.8/0.3 ²⁾	272894
D 	Bürkert Cartridge port connection	0.65	0.5	6.5	6	Vac-6 ¹⁾	12	0.7	273615
		0.65	0.5	6.5	6	Vac-6 ¹⁾	24	0.7	273614
T 	Bürkert Cartridge port connection	0.5	0.65	6	6	Vac-4 ¹⁾	24	0.7	292608

¹⁾ VAC corresponds to -0.8 bar relative

²⁾ External electric power reduction necessary

³⁾ Measurement at +20 °C, 6 bar pressure at the valve input and 1 bar pressure difference

Ordering chart Ex version

II 2G IIC T4...T6 / II 2D IIIB T155 °C

Circuit function	Port connection	Orifice ventilation 1-2	Orifice ventilation 2-3	Q_{Nn} value 1-2 air [l/min] ²⁾	Q_{Nn} value 2-3 air [l/min] ²⁾	Pressure range [bar]	Resistance with 20 °C [Ω]	Min. holding current [mA]	Article no. with connection pin
C 	Bürkert Cartridge port connection	0.5	0.65	6	9.5	Vac-6 ¹⁾	320	29	289027
							510	23	289028
D 	Bürkert Cartridge port connection	0.65	0.5	6.5	6	Vac-4 ¹⁾	320	29	on request

¹⁾ VAC corresponds to -0.8 bar relative

²⁾ Measurement at +20 °C, 6 bar pressure at the valve input and 1 bar pressure difference

Electrical Data:

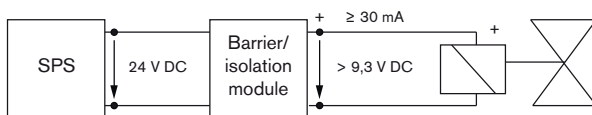

Functional value for valve at -10 °C to +55 °C		Maximum permitted levels/value pairs
Min. holding current	29mA	according to the user manual
Nominal coil resistance	320Ω	
Min. holding current	23mA	
Nominal coil resistance	510Ω	

Overview of accessories

Manifold fully sunken

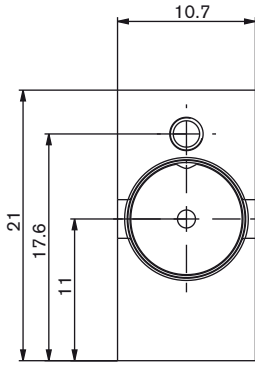

Locking

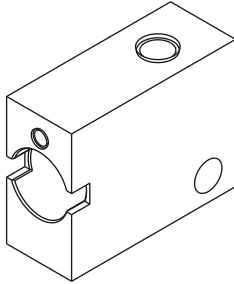
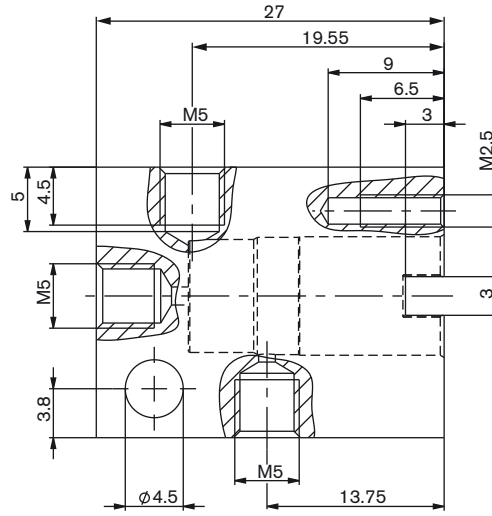

Note:
Max. tightening of the screws
(see manual)

Description	Article no.
Manifold 1 place, brass	695913
Spare part set for Type 6164	696033
Mounting bracket Set for Type 6164	696032
Plug IP40 for Type 6164	695951

Mounting bracket for semi-submerged configuration

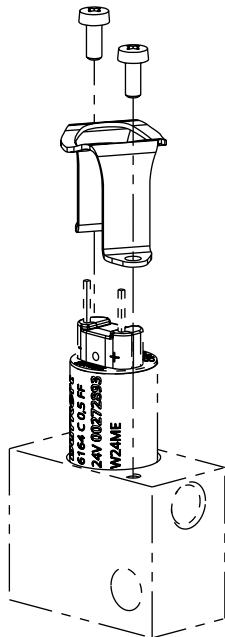

Spare part set O-ring and fixing screw

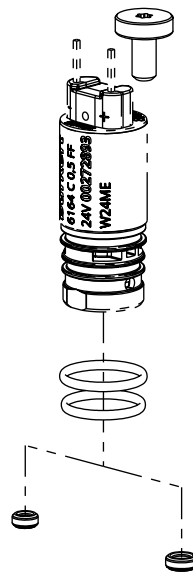

Plug with IP40 locking

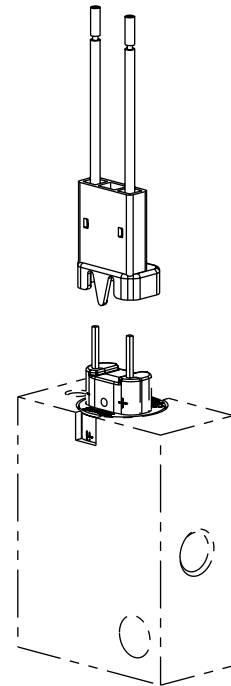

Application examples

Single block with Cartridge

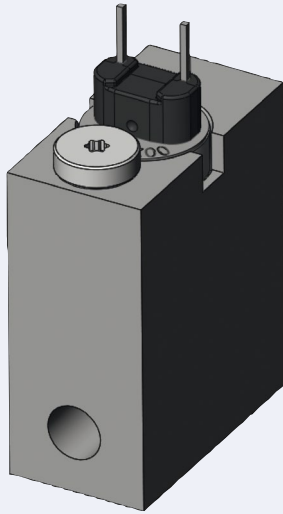

Cartridge installation position

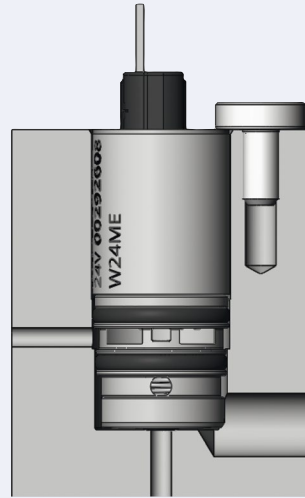

Fully sunken multi-manifold

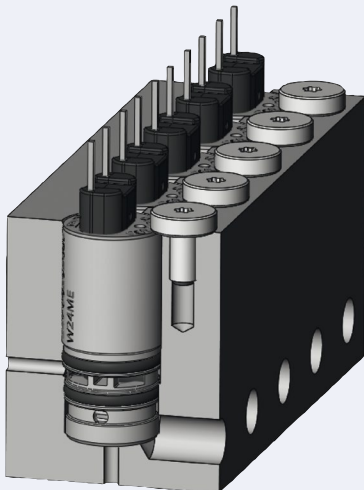

Semi-sunken multi-manifold

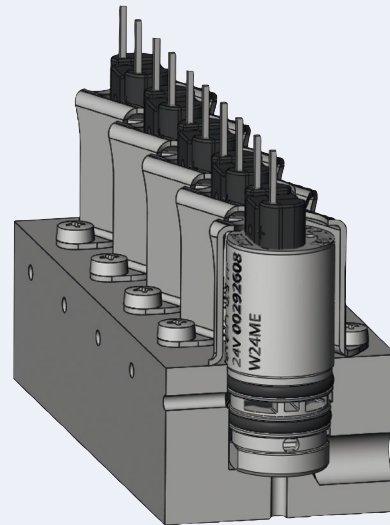

i Further versions on request

⚡ Voltage
Voltages 9 V, 6 V, 3 V

> Additional
Leads version

🔍 Oxygen compatibility
Suitable for the oxygen application
labeled with a blue sticker

To find your nearest Bürkert facility, click on the orange box → www.burkert.com

In case of special application conditions,
please consult for advice.

Subject to alteration.
© Christian Bürkert GmbH & Co. KG

1801/7_EU-en_00895290